

Suitable Applications For Duracrete Underground Water Tanks 12,500 Litre

Duracrete Underground Tanks are suitable for buried applications with 300mm maximum ground cover.

The roof is designed for light vehicle loading <2500kg.

*Please note the manhole riser and lid are not designed for vehicles.

Manhole lids are manufactured to take a maximum loading of 500kg



Example of completed installations

- 7.5 Tonne Weight
- 65mm Wall Thickness
- 100mm Floor Thickness
- 80 MPA Concrete Strength
- Manhole lid maximum loading capacity of 500kg

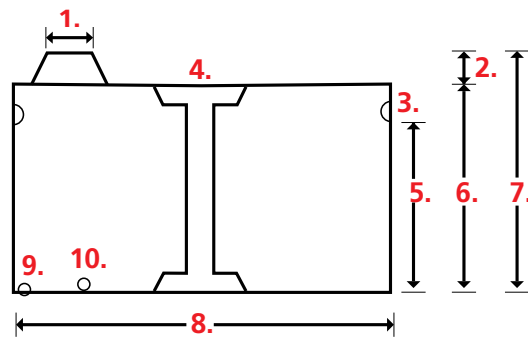

1. Hatch Opening	550mm
2. Permitted ground cover	300mm
3. Overflow/Inlet, 4 positions	110mm
4. Support column (diameter)	150mm
5. Water Level Height	1.25m
6. Total Wall Height	1.43m
7. Overall Height	1.73m
8. Outside Diameter	3.730m
9. Drain	50mm
10. Outlet	40mm

Light Vehicle Loading Roof Only (<2500kg gross weight) *Please note the manhole riser and lid are not designed for vehicles



Manhole lid maximum load capacity 500kg



Weight of soil 1800 kg/m³

300mm typical topsoil cover

Ground water level

1.2 max

Backfill with rock free material

Duracrete recommends using an Authorised Installer for site preparation & installation of tanks to safeguard your tank warranty.

INSTALLATION STEPS:



1 Level the ground which will form the base for your tank.

The base needs to be level in all directions.



2 The excavated hole should be square. The final size should be 4m x 4m x 1.9m deep.



3 Add hard fill and compact with a compactor.

Compact to a depth of 100mm thick.



4 Add 7mm Granular Fines as bedding material - this should be 75mm thick and be levelled in all directions with a straight edge and level.

The base fines (cushion course) and base course, should be back-filled and contained around the base of the tank, (or higher where appropriate), to ensure all site preparation material stays firmly in place.

SITE PREPARATION:

The site loading of a full 12,500 litre water tank is approximately 20 tonnes. This extreme loading requires particular care to distribute the load evenly across the site. Foundations must be 'good ground' in accordance with NZS 3604.

The site for your tank must be free of all solid objects (rocks, tree stumps, roots, etc) and be flat, level and consistent across the tank base to allow the tank to sit evenly. A tolerance of 15mm is permitted over the entire site. This can be achieved by using a level and straight edge, laser level or similar method.

Correct site preparation is critical in order to transfer the total combined weight of the tank and water of approx 20 tonne to the prepared foundation.

Uneven weight transfer will result in failure of the tank base and therefore will not be covered by warranty.

75mm layer of 7mm granular fines "PAP 7", Scoria Fines or similar is suitable.



100mm layer of hard fill - compacted "Blue Brown 40" or similar is suitable.

4m square base, levelled in all directions "Good Ground" in accordance with NZS 3604.

Aggregates are sold at Western Hills Quarry, Whangarei and other quarries throughout NZ

Duracrete recommend using an Authorised Installer for site preparation and installation of tanks to safeguard your tank warranty.





IMPORTANT NOTES:

1. Duracrete underground tanks with Central Support are designed to exceed Load Class A as specified in AS3996 Standard for Access Covers and Grates. "Note: Loaded contractors vans will probably exceed this weight.
2. Suitable site access is the responsibility of the purchaser. Check that there are no overhead wires, branches, buildings, gate posts or other obstacles blocking access to the loaded delivery truck. Our truck driver will take every care not to damage property but will not be responsible for damage caused due to restricted access.
3. Make sure the ground is firm enough to take the weight of a loaded truck. If you have any doubts raise them with us before delivery.
4. Make sure there are no holes, drains or septic tanks etc that the truck could fall into when delivering your tank.
5. **BURIED APPLICATIONS**
Any Duracrete tank that is buried requires to be filled with water at least 800mm higher than any anticipated ground water to prevent floatation, refer to Duracrete PS1 document in Technical Information Section of our website. www.duracrete.co.nz
6. It is important to pipe the overflow away from the tank site to prevent undermining of the site in any way. The overflow pipe must be installed before tank is filled with water on the day of installation

WARRANTY:

All Duracrete Products are warranted to be free of defects caused by poor workmanship or non-compliance with industry standards, for a period of 10 years from the date of purchase. This warranty is offered only to the original purchaser.

CONDITIONS OF WARRANTY:

1. 10 years to original owner / purchaser.
2. Duracrete Products accepts no liability for damage caused due to improper site preparation and incorrect site situations that are outside our requirements and recommendations. (Refer to site preparation .2)
3. Liability of Duracrete Products is limited to the repair, or if necessary, replacement of the concrete tank concerned. The decision to repair or replace the tank lies exclusively with Duracrete Products.
4. Preparation of the tank site is the responsibility of the purchaser or their agent, unless Duracrete agrees to undertake the work in writing.

THIS WARRANTY DOES NOT COVER:

- Damage caused after delivery resulting from poor or inadequate site preparations
- Moving the tank from its original location.
- Undermining of the ground supporting the tank in any way.
- Filling of tank with water past the overflow point before the overflow pipe is fitted.
- Installation of the partially buried tanks exceeding the recommended appropriate maximum ground level.
- Exceeding of the load capacity on manhole lid.
- Hydraulic Uplift (Floatation)
- Normal wear and tear.
- Negligent and accidental damage.
- Failure resulting from natural causes (earthquakes, flooding etc.)
- Repairs carried out by unauthorised persons.
- Use of a tank for purposes other than for which it was originally intended.

If you have any further queries regarding your site, delivery of your tank, or require further information on concrete water storage tanks, please feel free to contact us.