

Suitable Applications For Duracrete Underground Attenuation Tanks 9,000 Litre

Attenuation tanks are often required as part of building consents by local authorities.

The tanks capture storm water run off, then slowly release the water into stormwater infrastructure. This saves the stormwater from being overwhelmed.

Duracrete Underground Tanks are suitable for buried applications with 300mm maximum ground cover.

The roof is designed for light vehicle loading <2500kg.

*Please note the manhole riser and lid are not designed for vehicles.

Manhole lids are manufactured to take a maximum loading of 500kg

The 9000 litre tanks have been designed for a ground water level of 1.2m.

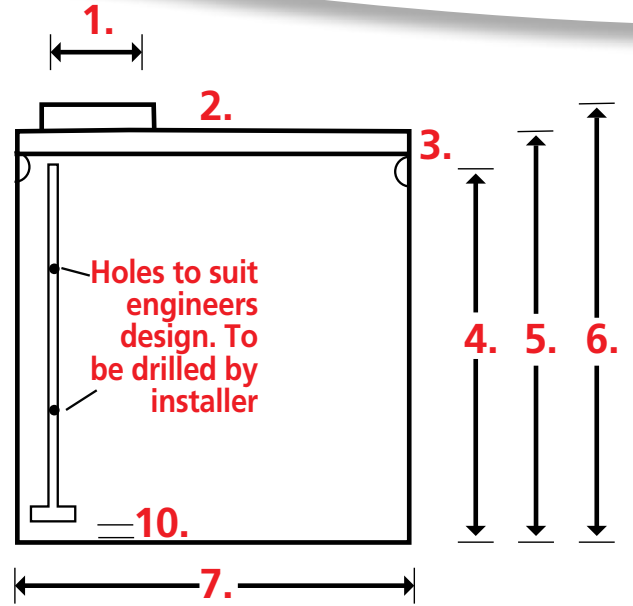

| | |
|--|-------|
| 1. Hatch Opening | 550mm |
| 2. Height of Riser | 250mm |
| 3. Overflow Inlet | 110mm |
| 4. Water Level Height | 1.95m |
| 5. Total Wall Height | 2.32m |
| 6. Overall Height | 2.57m |
| 7. Outside Diameter | 2.5m |
| 8. Height of 100mm PVC pipe off tank floor | 100mm |

Light Vehicle Loading Roof Only (<2500kg gross weight) *Please note the manhole riser and lid are not designed for vehicles



Manhole lid maximum load capacity 500kg



Weight of soil 1800 kg/m³

250mm typical topsoil cover

Ground water level

1200mm

Backfill with rock free material

- 4.8 Tonne Weight
- 65mm Wall Thickness
- 100mm Floor Thickness
- 80 MPA Concrete Strength
- Manhole lid maximum loading capacity of 500kg

Tank Warranty will be voided unless site preparation is carried out by a Duracrete approved earthworks contractor, in accordance with Duracrete's site preparation document. Please contact us and advise us of your proposed contractor.

SITE PREPARATION STEPS



1 Level the ground which will form the base for the tank. Excavate the virgin solid ground. Do not use excavated material to achieve a level platform. The tolerance allowed is 40mm.



2 The base should be a 2.8 meters x 2.8 meters square hole x 2.74m depth for 2.5m ø tanks.



3 Add hard fill and compact with a compactor. Compact to a depth of 100mm thick. The tolerance to be within 15mm.



4 Add 7mm GAP Granular Fines as bedding material - this should be 75mm thick. Do not compact, this should be screeded to within 5mm tolerance over the entire base.

SITE PREPARATION IMPORTANCE & REQUIRED MATEIALS

The site loading of a full 9,000 litre attenuation tank is approximately 14 tonnes This extreme loading requires particular care to distribute the load evenly across the site. Foundations must be 'good ground' in accordance with NZS 3604.

The site for your tank must be free of all solid objects (rocks, tree stumps, roots, etc) and be flat, level and consistent across the tank base to allow the tank to sit evenly. A tolerance of 15mm is permitted over the entire site. This can be achieved by using a level and straight edge, laser level or similar method.

Correct site preparation is critical in order to transfer the total combined weight of the tank and water of approx 14 tonne to the prepared foundation.

Uneven weight transfer will result in failure of the tank base and therefore will not be covered by warranty.

75mm layer of 7mm granular fines "PAP 7", Scoria Fines or similar is suitable.

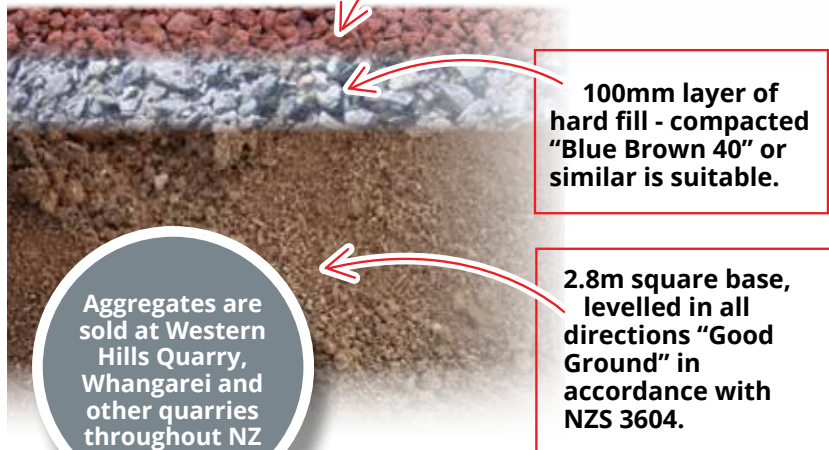

100mm layer of hard fill - compacted "Blue Brown 40" or similar is suitable.

2.8m square base, levelled in all directions "Good Ground" in accordance with NZS 3604.

Aggregates are sold at Western Hills Quarry, Whangarei and other quarries throughout NZ



WARRANTY TERMS & CONDITIONS:

All Duracrete Products are warranted to be free of defects caused by poor workmanship or non-compliance with industry standards.

CONDITIONS OF WARRANTY:

- Tank warranty will be voided unless site preparation is carried out by a Duracrete approved earthworks contractor, in accordance with Duracrete's site preparation document. Please contact us and advise us of your proposed contractor.
- Duracrete Products accepts no liability for damage caused due to improper site preparation and incorrect site situations that are outside our requirements and recommendations. (refer to site preparations points 1-4)
- Liability of Duracrete Products is limited to the repair, or if necessary, replacement of the concrete tank concerned. The decision to repair or replace the tank lies exclusively with Duracrete Products.

THIS WARRANTY DOES NOT COVER:

- Damage caused after delivery resulting from poor, inadequate or incorrect site Preparations in accordance with our PS1 document
- Tanks that are not placed directly on to a prepared tank site at the time of delivery.
- Damage caused during transportation or installation
- Moving the tank from its original location
- Undermining of the ground supporting the tank in any way
- Filling of the tank with water past the overflow point before the overflow pipe is fitted
- Blocked or incorrectly installed overflow pipe. This includes backlog of groundwater from full soakage pits and the overflow pipe not being installed to drain away from the tank base.
- Installation of the partially buried tanks exceeding the maximum ground level as per our specifications
- Exceeding of the load capacity on the manhole lid
- Hydraulic Uplift (Floatation)
- Normal wear and tear. Aging.
- Negligent or accidental damage that occurs after delivery
- Failure resulting from natural causes (earthquakes, flooding, ground settlement/subsidence and temperature differential)
- Tanks that are unequally buried that have a greater differential of more than 1m from highest to lowest point
- Tanks that are painted a dark colour that attracts heat, causing the temperature differential between the inside and outside of the tank to increase
- Damaged caused to the roof of the tank due to the exceeding of the load limitations (refer to PS1 document)
- Failure of any plumbing or drainage connections installed by others after delivery



PURCHASER RESPONSIBILITIES:

- It is the purchasers responsibility to ensure access is clear and site preparations are complete and to the required standard when the tanks arrive. This will avoid any delays and extra time on site and potential cost overruns. Duracrete and your chosen Transport Contractor takes no responsibility for site readiness or unforeseen delays on site
- Site suitable access is the responsibility of the purchaser. Check that there are no overhead power lines, tree branches, buildings, gate posts or other obstacles blocking access to the loaded delivery truck
- Duracrete and your chosen Transport contractors that are used to deliver the tanks are not responsible or liable for the site preparation standards
- On the day of installation, it is essential to install and pipe the overflow away from the tank base to prevent undermining of the site
- On the day of installation of fully or partially buried tanks (up to 2.1ml, it is critical that the tanks are filled completely with water not exceeding the overflow point to prevent floatation from occurring. The tanks should remain full until connected to the water catchment
- When purchasing multiple tanks, ensure that there is an accessible isolation valve between the tanks in order to be able to isolate one tank from the other for future maintenance purposes
- For buried applications, tanks buried 800mm or more into the ground may require a specific design to avoid hydraulic uplift occurring. Please refer to an engineer to decide if your tank requires this. Duracrete is not responsible for determining if your tank requires this
- It is the purchaser's responsibility to ensure that the path required from the road to the tank site does not have drains, septic tanks or irrigation lines that the truck could either fall into or damage
- It is the purchasers responsibility to ensure that their site access and tanks sites are ready to take delivery on the agreed date with our Production/Dispatch Manager. If there is a delay, you may move to the back of the que depending on product and transport contractor availability. Product may then need to be allocated to the next customer who is ready to take delivery as we can not store tanks due to storage space limitations
- It is the purchasers responsibility to pass these specifications, warranty terms and conditions and customer responsibilities document on to any relevant contractors or end users.